

Millars

MILLARS INDIA LIMITED



MOBILE PLANTS



Millars

MILLARS INDIA LIMITED

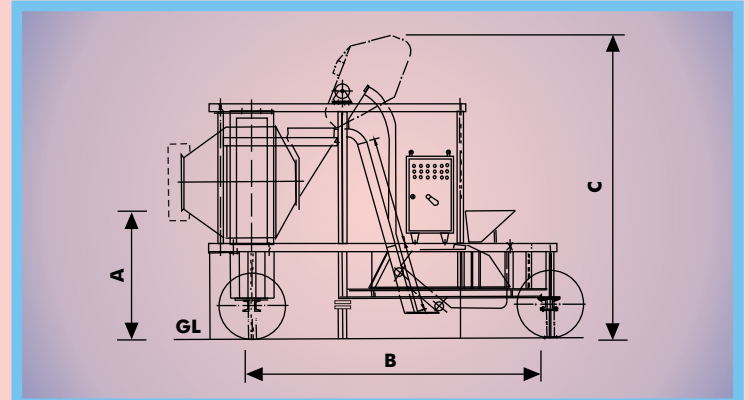
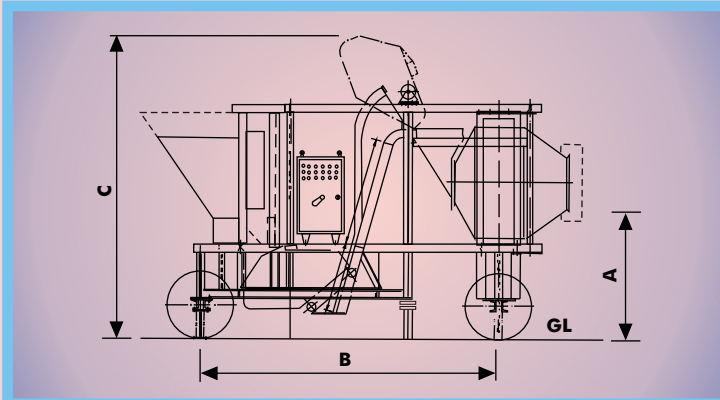

- a) Mobile Concrete Batching & Mixing Plant with Starbin hopper & Cement Screw Conveyor.
- b) Weighing by Electronic load cell + Microprocessor.
- c) Mechanical Weighing System with Dial is Optional.

Mobile mixer with electronic weigh Batcher & Microprocessor.

MODEL	Max CAPACITY	Revenue by Mixer Cap/Output Batch	TOTAL APPR. STAR BIN HOPPER CAP.		APPR. DIMENSIONS			HORSE POWER for				
			With out Extension	With Extension (Optional)	A Dis. HT.	B Wheel Base	C O/A HT.	Mixer	Skip	Compre SSOR	Water Pump	Inclined S-Conveyer
375/500	10m ³ / HR	0.375 m ³	4.5 m ³	5.5 m ³	1700	4150	4100	7.5	7.5	3	3	3
500/750	15m ³ / HR	0.500 m ³	7.5 m ³	10 m ³	2050	4880	5500	12.5	12.5	3	3	3
750/1000	20m ³ / HR	0.750 m ³	7.5 m ³	10 m ³	2250	5915	6100	15	15	3	3	3
1000/1500	30m ³ / HR	1.0 m ³	7.5 m ³	10 m ³	2400	5915	6100	25	20	3	5	5

Recommended Maximum Towing speed 6 km/HR

Millars

MILLARS INDIA LIMITED

24, Kurla kirol Road, P.O. Box No 9208, Ghatkopar (W), Mumbai - 400 086.

Tel : + 91 22 2509 4145 / 2509 0656 : Fax : 022 2511 5057 : e mail : millars@vsnl.net.

Factory : Anand Sojitra Road, Karamsad, Gujrat - 388 325.